

Hi-Res VGA USB KVM Extender via CAT5

XTENDEX®

Extend USB keyboard, USB mouse and VGA monitor up to 1,000 feet (305 meters)

- Industry-leading ultra high resolutions up to 2048x1536.
- High quality, rugged steel construction with durable powder coat finish.
- Automatically adjust video quality and color skew for crystal clear video with longer cables.
- DDC2B emulation support for remote monitor.
- Built-in surge protection.
- Available with optional stereo audio and/or additional USB 2.0 (low/full speed) port for local and remote user.
 - For the additional USB port on the local unit, connect any type of USB device (fully transparent USB connection).
 - For the additional USB port on the remote unit, use to connect a USB printer, touch screen monitor, interactive whiteboard, or CAC card reader.
- Integrated mounting brackets for easy surface/wall mounting.



XTENDEX® ST-C5USBVUA-1000S Local and Remote Units

The XTENDEX® VGA USB KVM Extender provides local and remote KVM (USB keyboard, USB mouse and VGA monitor) access to a USB computer or NTI KVM switch up to 1,000 feet (305 meters) using CAT5/5e/6 UTP cable. Each ST-C5USBV-1000S consists of a local unit that connects to a computer and provides local keyboard, monitor and mouse connections, and a remote unit that connects to a keyboard, monitor and mouse. The local and remote units are interconnected via CAT5/5e/6 cable.

Available options:

- **Audio**
- **USB connector for USB printer, touch screen monitor, CAC card reader, or interactive whiteboard**

Specifications

Local Unit

Host Connection

- Supports a USB computer (PC, SUN, MAC).
- Multiplatform support: Windows 7/8/10/11, Windows Server 2008/2012/2016/2019/2022, Solaris, Linux, FreeBSD, and MAC OS 10/11/12/13.
- One male 15-pin HD connector.
- One male USB Type A connector.
- Audio option (ST-C5USBVUA-1000S): one 3.5mm stereo plug (audio in).

Local Access

- Crisp and clear 2048x1536 video resolution.
- One female 15-pin HD connector.
- Two female USB Type A connectors.
- Available with optional stereo audio and additional USB port for local and remote user (ST-C5USBVUA-1000S).
 - ◆ One 3.5 mm stereo plug (audio out).
 - ◆ One female USB Type A connector for an additional USB device.
 - ◆ Connect any type of USB device – fully transparent USB connection.
 - ◆ USB maximum data rate: 12 Mbps

Video Quality Adjustment

- Automatically adjusts the video quality and color skew to compensate for varying lengths of CAT5/5e/6 cable.
 - Maximum delay: 62ns in 2ns steps.
- Manual fine adjustments are made via keyboard commands.
- Settings are automatically stored in the unit. The next time the unit is powered on, the adjustment will be recalled.

MTBF

NTI Part #	Hours	NTI Part #	Hours
ST-C5USBV-L-1000S	38,570	ST-C5USBV-R-1000S	43,429
ST-C5USBVUA-L-1000S	37,838	ST-C5USBVUA-R-1000S	42,606

Remote Unit

- Supports resolutions up to 2048x1536; refer to the resolution chart for resolutions at different lengths.
- One female 15-pin HD connector.
- Two female USB Type A connectors.
- Available with optional stereo audio and additional USB port for local and remote user (ST-C5USBVUA-1000S).
 - One 3.5 mm stereo plug (audio out).
 - One female USB Type A connector for an USB (low/full speed) device – USB printer, touch screen monitor, CAC card reader, interactive whiteboard, or barcode scanner.
 - ◆ USB maximum data rate: 12 Mbps.
 - ◆ When using a USB printer connected from the remote unit, it is recommended to only print three pages at a time.
 - ◆ Supported touch screen monitors: Microtouch 3M, Elo 1529L 3000 Series, ELO 3202L, Elo 1515L, Dell S2240T, Smart Podium ID422w, Hope Industrial HIS-RL17, NEC MultiSync E222W, Industrial Electronic Devices Inc IWS-240T-G3, Zytronic CML-170, Pulse IR TSV4001/DT40, HP Compaq, Sharp Aquos Board, Advantech FPM-2150, Touch Screens Inc TWAP-1150ADP/1154ADP-USB and similar monitors that use PenMount 5000/6000/9000 driver.
 - ◆ Supported interactive whiteboards: SMART Board™ SB640
 - ◆ Supported card readers: Athena, Cherry, Gemalto, Generic USB, and Dell smart card/keyboard combo.

Environmental

- Operating temperature: 32 to 100°F (0 to 38°C).
- Storage temperature: -22 to 140°F (-30 to 60°C).
- Operating and storage relative humidity: 5 to 90% non-condensing RH.

Dimensions

- WxDxH: 5.1x3.1x1.2 in. (130x79x31 mm)

Power

- Local and remote unit: 100 to 240 VAC at 50 or 60 Hz via AC adapter.

Regulatory Approvals

- CE, RoHS
- TAA compliant

Hi-Res VGA USB KVM Extender via CAT5 XTINDEX®

Extend USB keyboard, USB mouse and VGA monitor up to 1,000 feet (305 meters)

Configuration and Cable Illustration

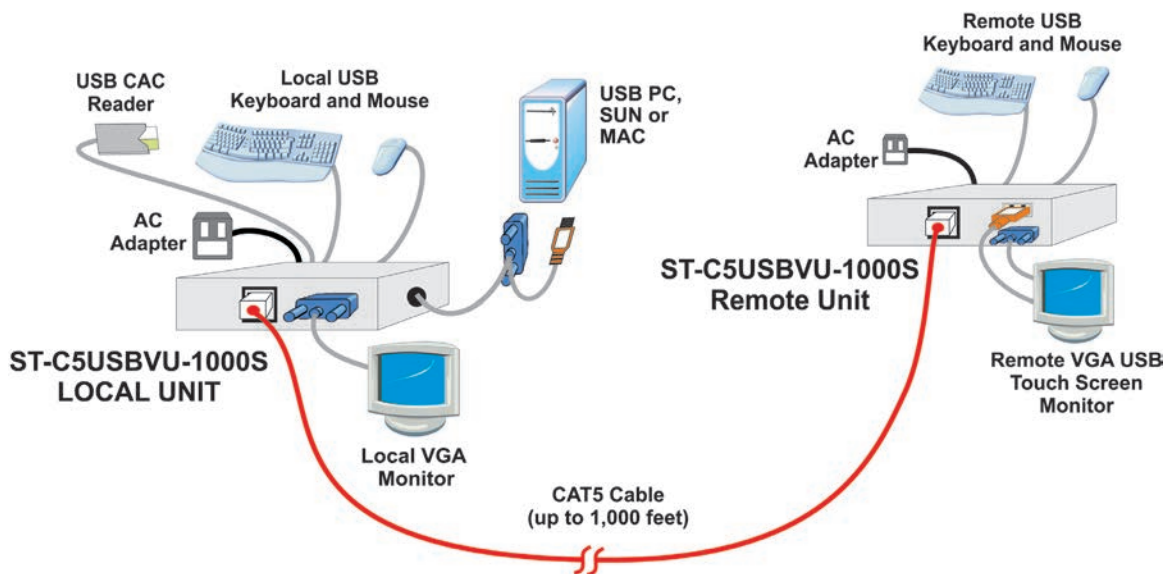

Options

Stereo Audio

- Stereo audio can be heard both locally and remotely.
- Frequency response: 20 Hz to 20 kHz, ± 1 dB.
- Signal-to-Noise Ratio (SNR): >76 dBA.
- Total Harmonic Distortion and Noise (THD+N): <0.1%.
- Stereo crosstalk: -70 dB.
- Input impedance: 10k Ohms.
- Line level output; supports multimedia speakers.
- Maximum I/O levels: 3.1Vp-p (line level).
- CD quality audio output.

Additional USB Port

- Additional USB 2.0 port for local and remote user.
 - For the additional USB port on the local unit, connect any type of USB device (fully transparent USB connection).
 - For the additional USB port on the remote unit, use to connect a USB printer, touch screen monitor, CAC card reader, interactive whiteboard, or barcode scanner.
 - ◆ USB maximum data rate: 12 Mbps.
 - ◆ When using a USB printer connected from the remote unit, it is recommended to only print three pages at a time.
 - ◆ Supported touch screen monitors: Microtouch 3M, Elo 1529L 3000 Series, ELO 3202L, Elo 1515L, Dell S2240T, Smart Podium ID422w, Hope Industrial HIS-RL17, NEC MultiSync E222W, Industrial Electronic Devices Inc IWS-240t-G3, Zytronics CML-170, Pulse IR TSV4001/DT40, HP Compaq, Sharp Aquos Board, Advantech FPM-2150, Touch Screens Inc TWAP-1150ADP/1154ADP-USB and similar monitors that use PenMount 5000/6000/9000 driver.
 - ◆ Supported interactive whiteboards: SMART Board™ SB640
 - ◆ Supported card readers: Athena, Cherry, Gemalto, Generic USB, and Dell smart card/keyboard combo.

Distances and Resolutions for CAT5/CAT5e and CAT6 Cables

Cable	Distance (ft)	Resolution
CAT5/CAT5e (UTP)	1000	1920x1200 at 60Hz
	800	1920x1440 at 60Hz
	600	2048x1536 at 60Hz
CAT6 (UTP)	800	1920x1440 at 60Hz
	600	2048x1536 at 60Hz
CAT5/5e (STP)	800	1920x1200 at 60Hz
	600	1920x1440 at 60Hz
	400	2048x1536 at 60Hz
CAT6 (STP)	400	1280x1024 at 60Hz
	300	1600x1200 at 60Hz
	200	2048x1536 at 60Hz

VGA USB KVM Extender Models

Supported Features	NTI Part #
USB KVM	ST-C5USBV-1000S
USB KVM + ADDITIONAL USB PORT + AUDIO	ST-C5USBVUA-1000S