



**NETWORK
TECHNOLOGIES
INCORPORATED**

1275 Danner Dr Tel:330-562-7070
Aurora, OH 44202 Fax:330-562-1999
www.networktechinc.com

ENVIROMUX-FAKCR

Finger Print Access and Key Card Reader System



1. Equipment Installation

Wall mount installation

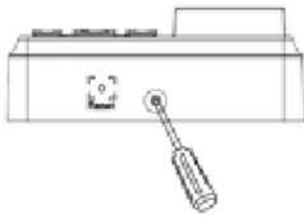

(1) Remove the screw on the bottom of device.

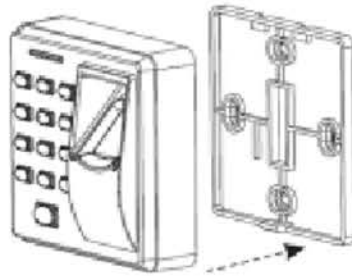

(2) Take away the back cover.



(3) Fix the back cover on the wall according to the mounting paper.



(4) Fix the device to the back cover.

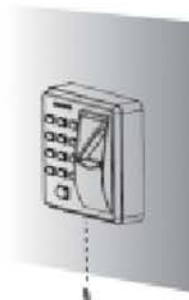

(5) Fix the screw.

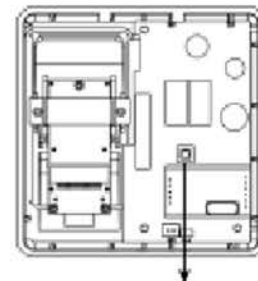

Tamper Switch

2. Structure and Function

Access Control System Function:



(1) If a registered user is verified, the device will send a signal to unlock the door.

(2) Door sensor will detect the door is open or not. If the door is unexpectedly opened or improperly closed, the alarm will be triggered.

(3) If the device is dismantled, it will send an alarm signal.

(4) It supports Exit Button; it is convenient to open the door inside.

(5) It supports Door Bell; visitors could call by the door bell.

3. Lock Connection

Warning: No operation when power on!

- (1) The system supports NO LOCK and NC LOCK. For example the NO LOCK (normally open at power on) is connected with **NO** terminal, and the NC LOCK is connected with **NC** terminal.
- (2) When the Electrical Lock is connected to the Access Control System, you need to parallel one FR107 diode (equipped in the package) to prevent the self-inductance EMF affect the system, do not reverse the polarities.

✧ **Share power with the lock:**

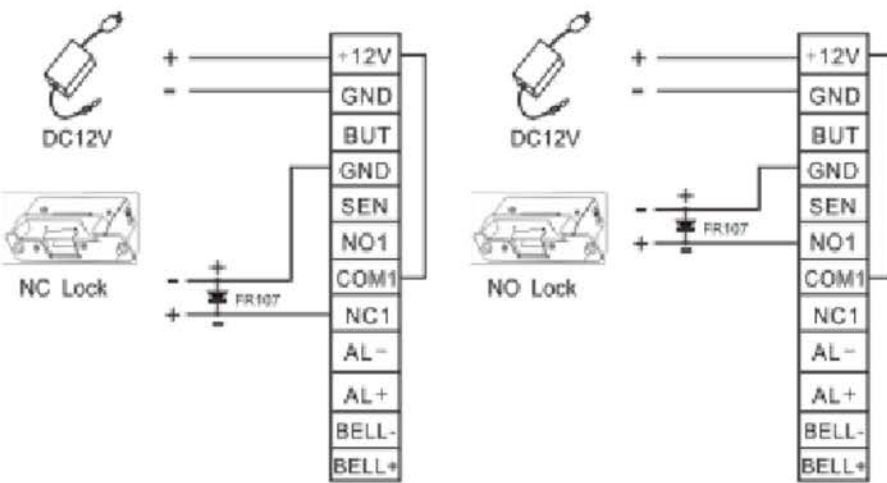

Device share power with the lock:
 $U_{LOCK}=12V, I_{LOCK}>1A...$ ①
 And the lock is near to the device.

We recommend that if you wire the Electric Lock directly to the ENVIROMUX-FACKR (instead of using the diagrams at the end of this manual), you should also install an external 12VDC power supply (sold separately, contact NTI).

✧ **Does not share power with the lock:**

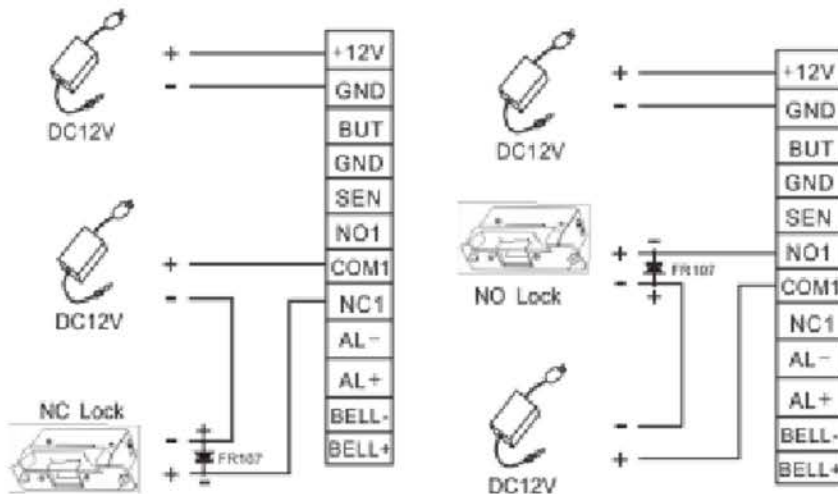

Device does not share power with the lock:

- $U_{LOCK}=12V, I_{LOCK}\leq 1A;$
- $U_{LOCK}\neq 12V;$
- The lock is far apart from the device.

① I: device output current, U_{LOCK} : lock voltage, I_{LOCK} : lock current.

4. Connected with Other Parts

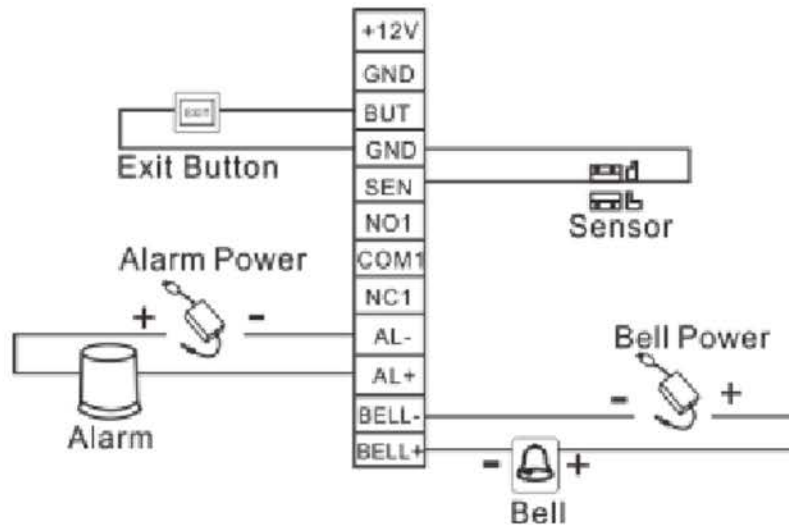

Voltage output \leq DC 12V for Alarm and Bell

5. Connect with Power

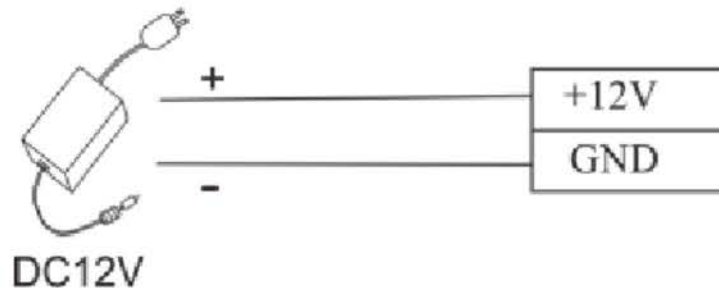

Input DC 12V, 500mA (50mA standby) Positive is connected with **+12V**, negative is connected with **GND** (do not reverse the polarities).

Instructions

Step 1: Power on after the device is completely installed on the wall.

Step 2: Change the administrator password, and configure access control parameters, including unlocking duration, authentication mode, concealed mode, door sensor mode, and alarm etc.

Step 3: Register users' cards, fingerprints or eight passwords.

Functions of the Device

| —1.User Management

- | | —1.1 Administrator Operations
 - | | | —❖ Administrator Authentication
 - | | | —❖ Change Administrator Password
 - | | | —❖ Open the Door by the Administrator Password
 - | | | —❖ Administrator Password Be Forgotten
- | | —1.2 Add Users
 - | | | —❖ Add Users
 - | | | —❖ Register Cards in Batches
- | | —1.3 Register Eight Passwords for Opening the Door
- | | —1.4 User Authentication
- | | —1.5 Delete Users
 - | | | —❖ Delete a User
 - | | | —❖ Delete All Users

| —2.Access Control Management

- | | —2.1 Configure Unlocking Duratio
- | | —2.2 Configure Authentication Mode
- | | —2.3 Configure Concealed Mode
- | | —2.4 Configure Door Sensor Mode
- | | —2.5 Configure Alarm
 - | | | —❖ Configure Alarm setting
 - | | | —❖ Configure Error Operation-Triggered Alarm
 - | | | —❖ Configure Tamper Alarm
 - | | | —❖ Configure Alarm Delay for the Door Status Sensor

Operation Instructions

1. User Management

1.1 Administrator Operations

To ensure data security of the device, you can operate the device only after the administrator password is authenticated.

❖ Administrator Authentication

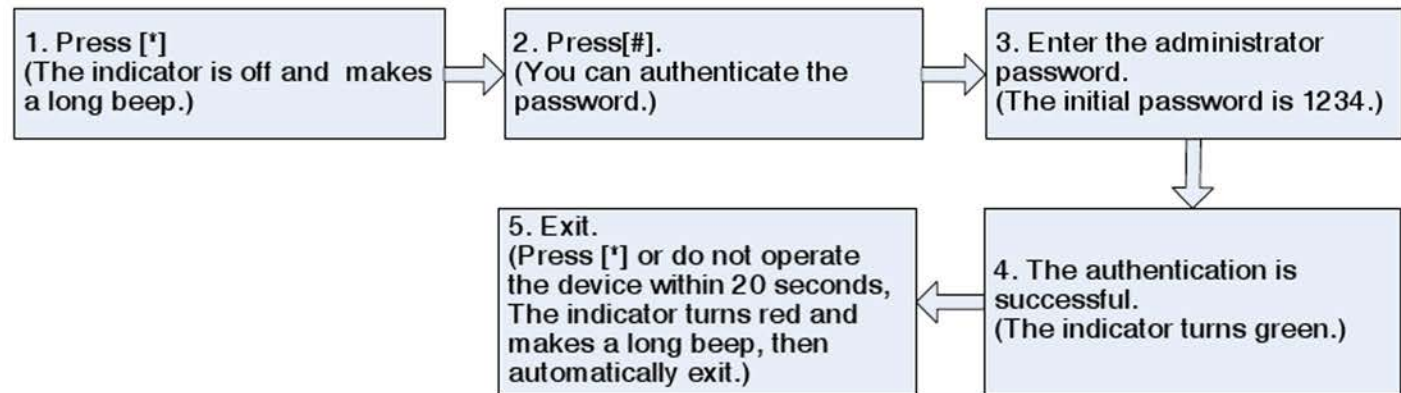

Note: The initial administrator password is 1234. You are advised to change the initial password at the beginning.

❖ Change Administrator Password

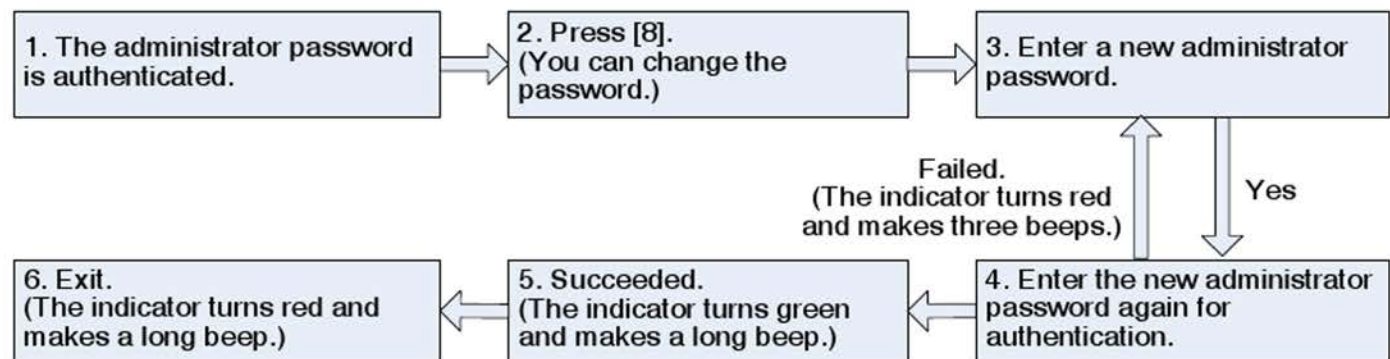

Note: Four-digit passwords are automatically verified. If passwords less than four digits, press [#] to confirm.

❖ Open the Door by Entering the Administrator Password

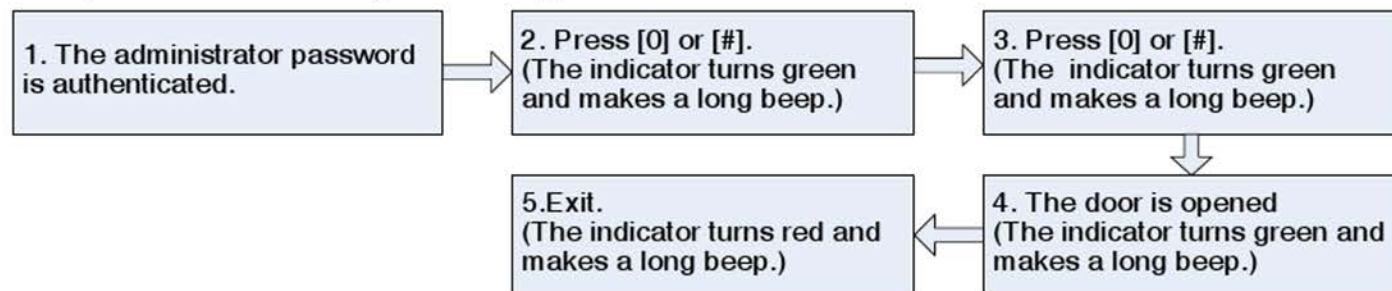

Note: This function can be used to open the door.

❖ Administrator Password Is Forgotten?

If the administrator password is forgotten, please dismantle the device and wait 30 seconds when there is a short beep, then press the Tamper Switch three times to reset to the initial administrator password, note this operation must be done within 30 seconds.

Note: The initial administrator password is 1234.

1.2 Add Users

Register the fingerprint or card of a user or register cards in batches.

❖ Add Users

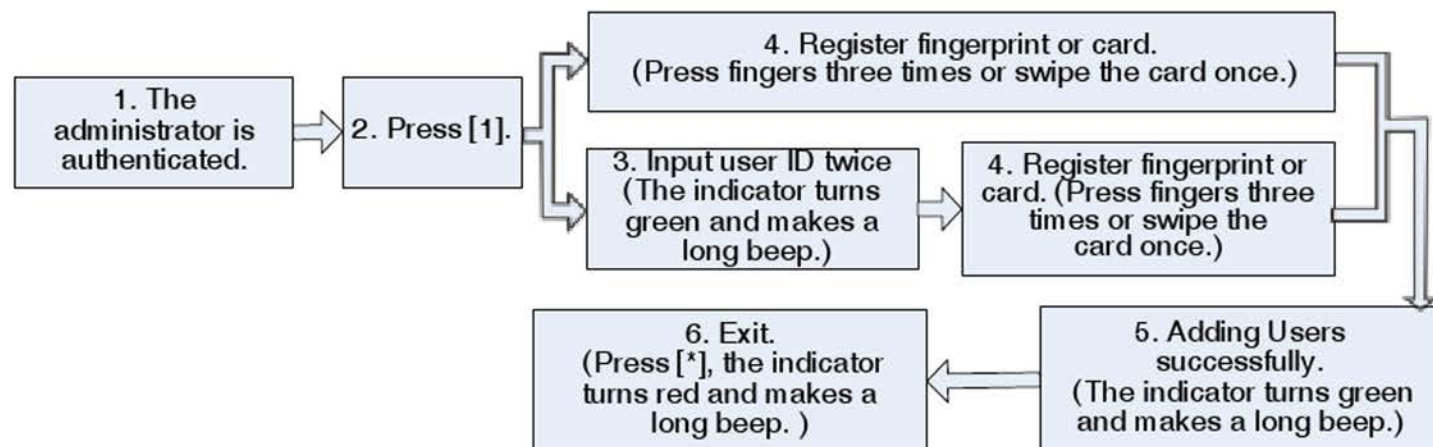

Note:

1. Press [#] to confirm after the user ID is entered.
2. If the user ID is not available, the ID number increases automatically. It continues to register new one once a user is successfully registered.

3. The registration fails if the user ID, fingerprint or the card has been registered (the indicator turns red and makes three short beeps). When the indicator turns green, you can register the user again. If you fail in swiping card, pressing fingerprint or entering user ID three times, the device will enter the standby state.

❖ Register Cards in Batches (optional functions)

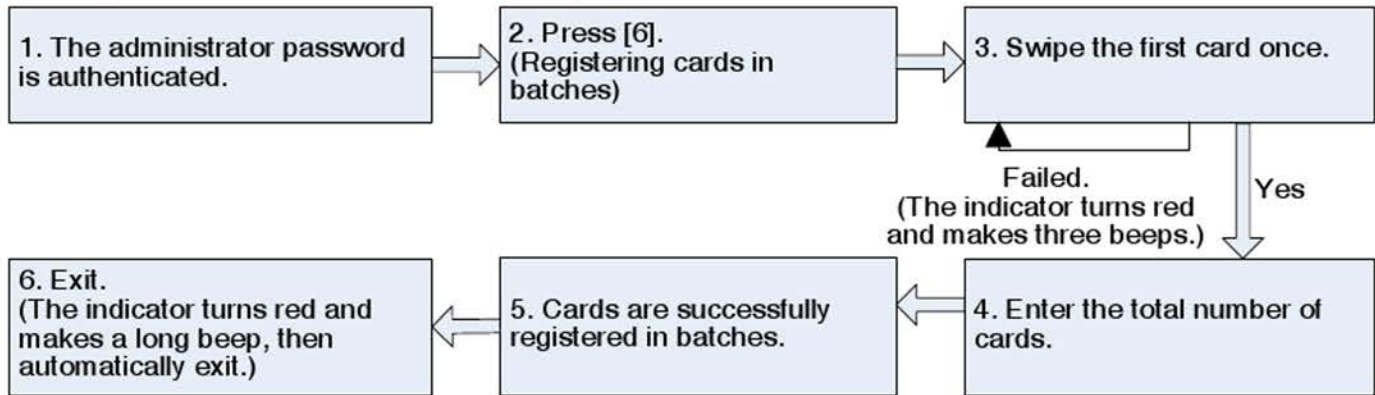

Note:

1. In the process of entering the total number of cards, three-digit numbers are automatically verified. For numbers with less than three digits, press [#] to confirm. Press [*] to reenter the total number of cards.
2. You must clear all the registered users before registering cards in batches. IDs of to-be-registered cards must be consecutive numbers.

1.3 Register Eight Passwords for Opening the Door

This device supports 8 passwords, each password has a Group ID ranges from 1~8. The default password value is 0 for all groups, which means passwords are disabled. You can modify the passwords under 8 groups to open the door.

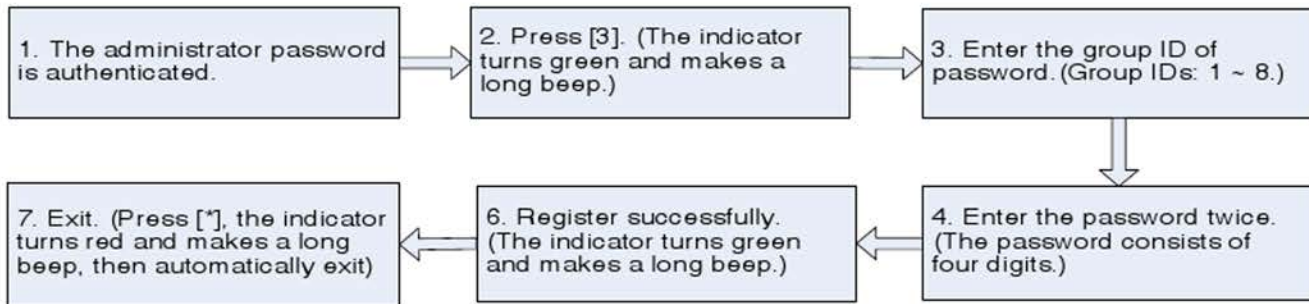

Note: If a password is successfully changed, enter the Group ID to change next one.

1.4 User Authentication

Card / Fingerprint / Password Authentication

After the device is powered on, it enters the authentication state for users to unlock the door.

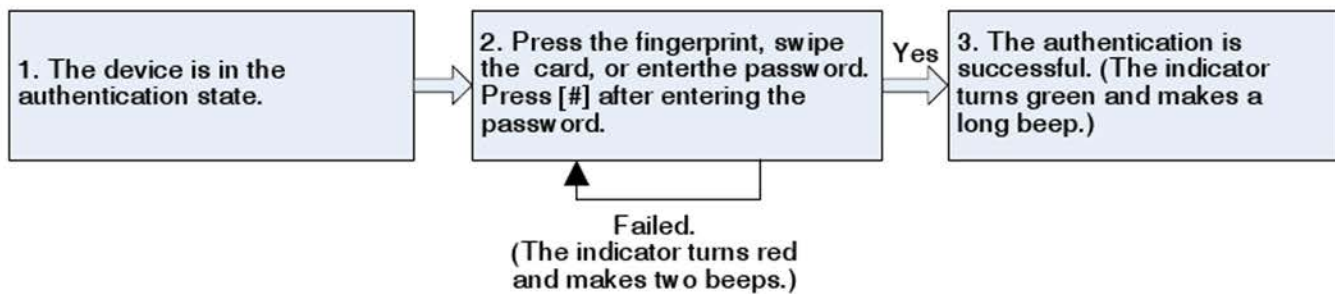

Note: Press [#] after entering a password for authentication. The door opens if the entered password is identical with one of the eight passwords for opening the door. The initial eight passwords for opening the door are empty.

1.5 Delete Users

Delete a user whose fingerprint or card is registered, or delete all users.

❖ Delete a User

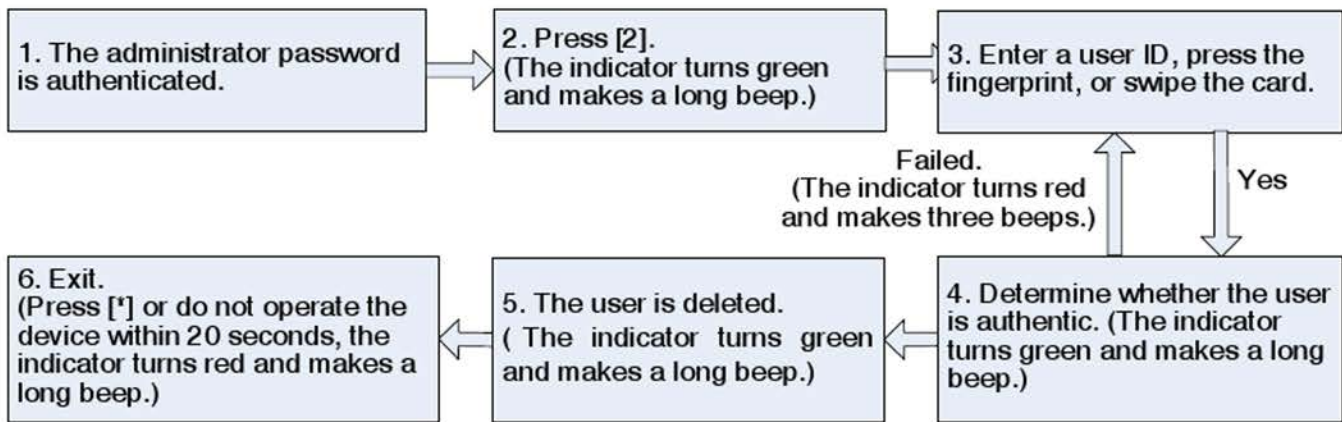

Note:

1. You can swipe the card, press fingerprint or input user ID to delete a user. Five digits user ID is automatically verified, if user ID is less than five digits, press [#] to confirm.
2. The device automatically enters the process of deleting the next user when a user is deleted, or press [*] to exit.

❖ Delete All Users

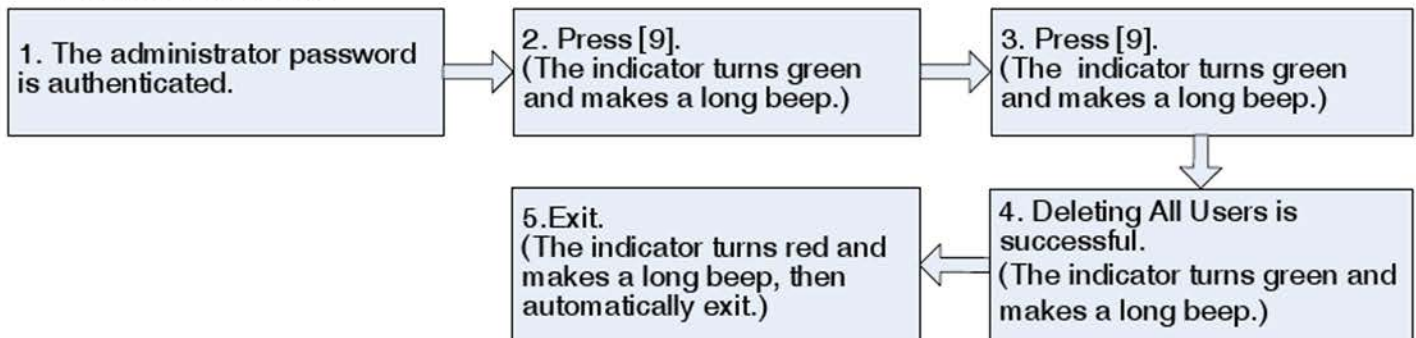

Note: Press [9] for automatic confirmation. Other values are considered invalid. If an invalid value is entered, the device indicator turns red, and the device makes a long beep and exits the process.

2. Access Control Management

2.1 Configure Unlocking Duration

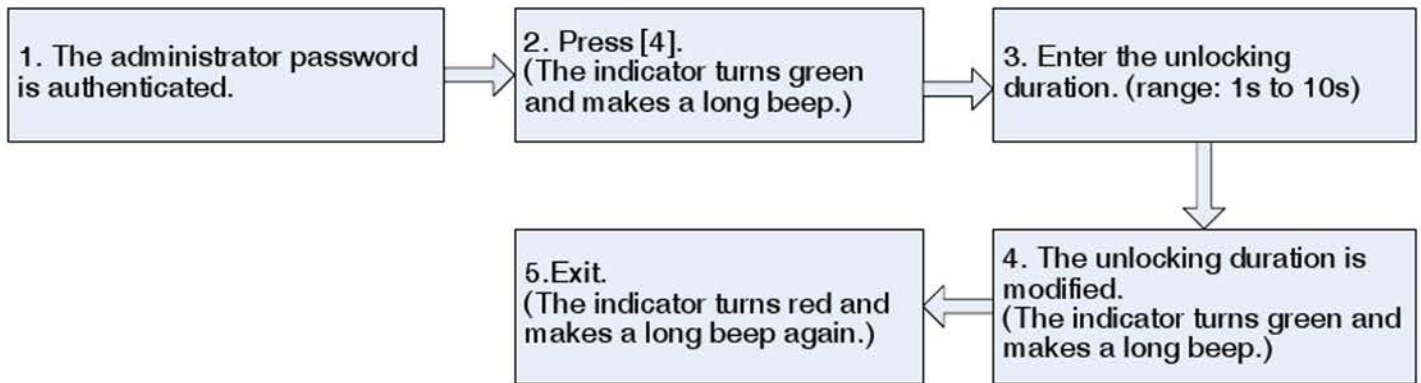

Note: Press [10] for automatic confirmation. For values with less than 10, press [#] to confirm. Values greater than 10 are considered invalid.

2.2 Configure Authentication Mode

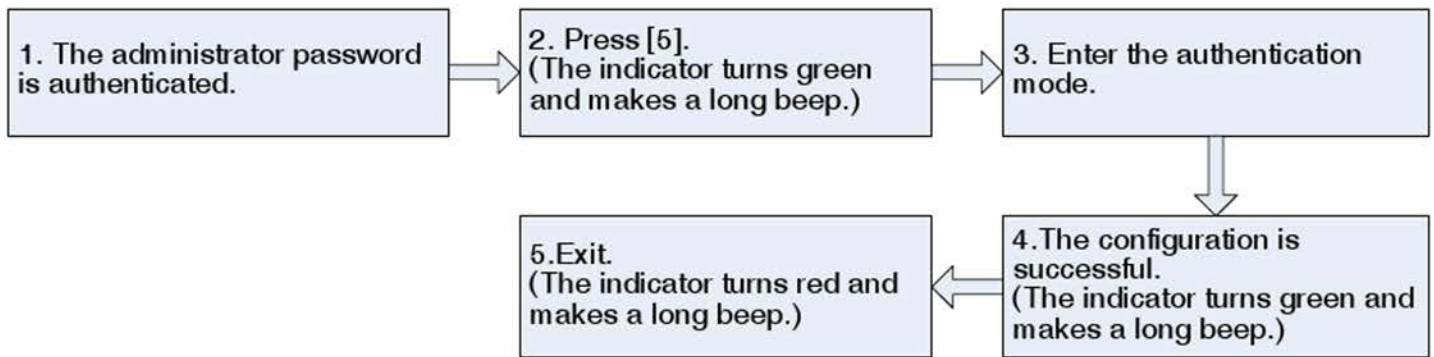

Note: Details about the authentication mode are as follows:

Authentication Mode	Value	Description
PW	1	Only password verification
RF	2	Only RF Card verification
FP	3	Only fingerprint verification
FP/PW/RF	4	fingerprint or password or RF verification
RF&PW	5	RF and password verification (swipe card before entering password)
FP&PW	6	fingerprint and password verification (fingerprinting before entering password)

2.3 Configure Concealed Mode

If the Concealed mode is enabled, the indicator is off.

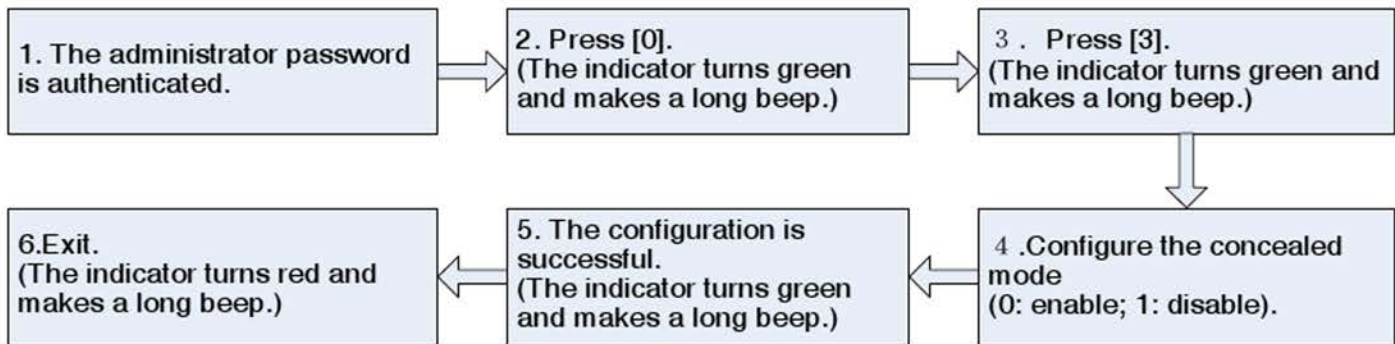

Note: An indicator blinks to indicate the status of this function when users are authenticating their cards or fingerprints or passwords.

2.4 Configure Door Sensor Mode

The door sensor has three modes:

- **NONE:** The door sensor is disabled.
- **NO (Normally Open):** The door sensor will send an alarm signal if it detects the door is closed.
- **NC (Normally Close):** The door sensor will send an alarm signal if it detects the door is open.

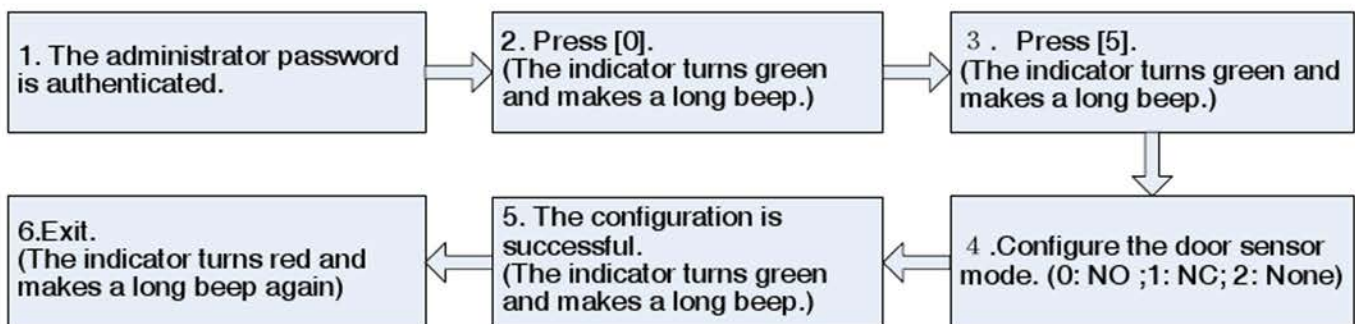

Note: The door sensor mode configured here is used as the basis for the door sensor alarm.

2.5 Configure Alarm

Note: If an alarm is triggered, the alarm can be terminated after the user is authenticated.

❖ Configure Alarm setting

The alarm switch is turned on by default. When it's disabled, the Error Operation-Triggered Alarm, Tamper Alarm, the Alarm Delay for the Door Status Sensor will be disabled.

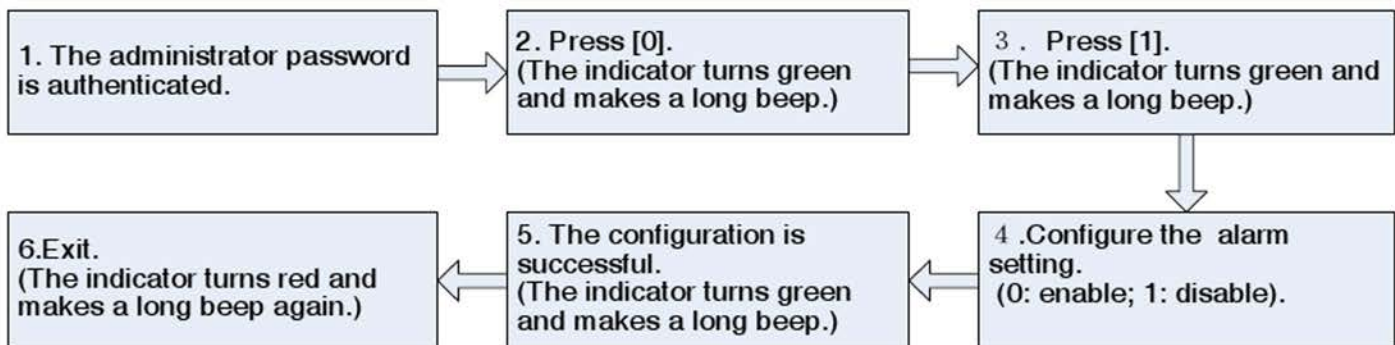

❖ Configure Error Operation-Triggered Alarm

If this function is enabled, alarms will be generated if the administrator fails the authentication upon three attempts; the administrator authentication is not allowed within 20 seconds after an alarm is generated.

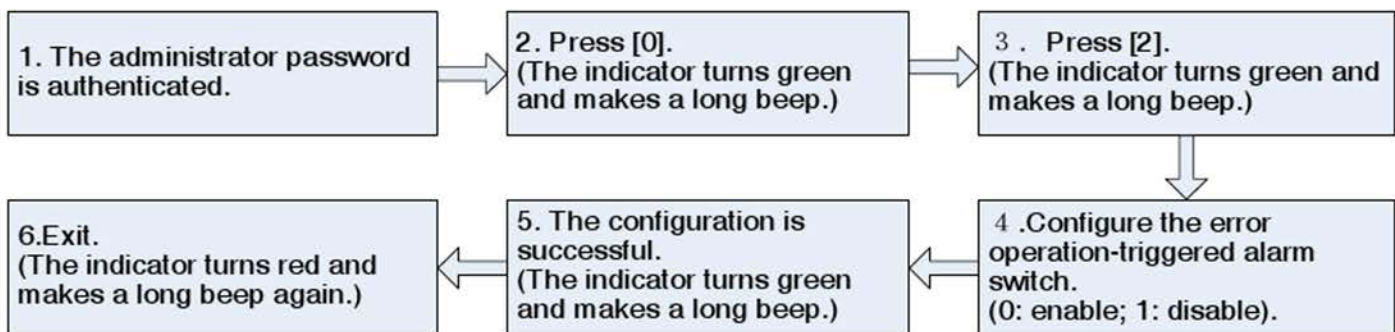

❖ Configure Tamper Alarm

If this function is enabled, alarms will be generated when device is dismantled from the wall.

Configure whether to enable the disassembly alarm.

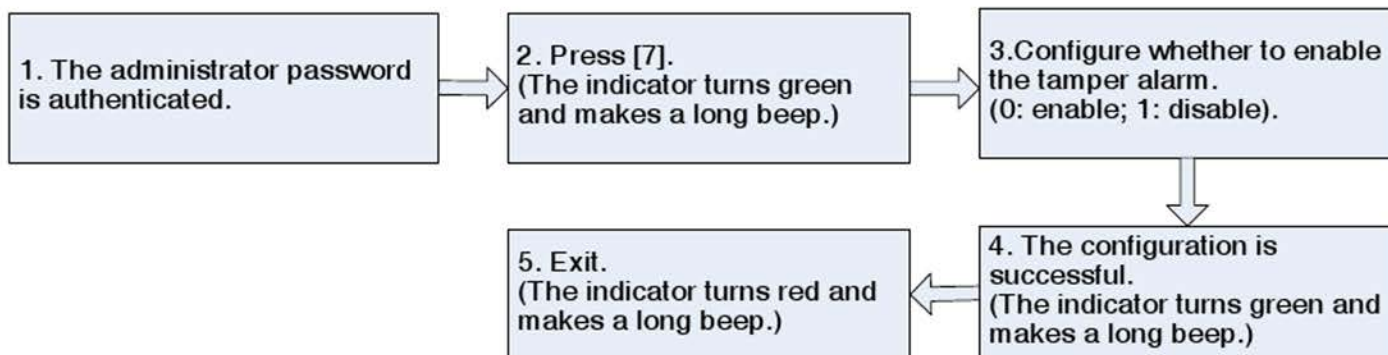

❖ Configure Alarm Delay for the Door Status Sensor

DSen. Delay (Door Sensor Delay):

It is to configure the time how long would the door sensor to check the door status.

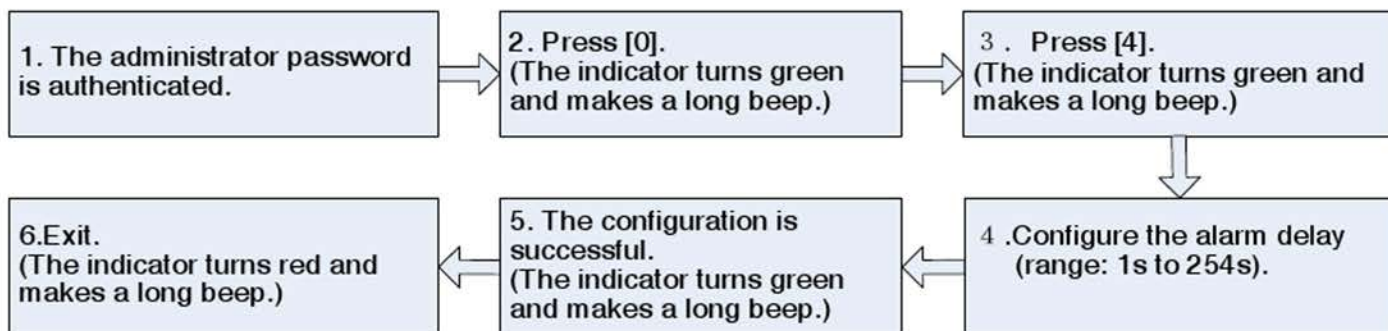

Note:

1. Three-digit values are automatically verified. For values with less than three digits, press [#] to confirm. Values greater than 254 are considered invalid.
2. When an alarm is triggered, the device interior alarm will be triggered first, then 30 seconds later, the device exterior alarm equipment will be triggered.

WIRING INSTRUCTIONS- ENVIROMUX-FACKR TO ENVIROMUX-2D/5D/16D

Also includes ENVIROMUX-EDR-SCR and ENVIROMUX-EDR-SF Electric Strikes

ENVIROMUX-FACKR Wiring Harness

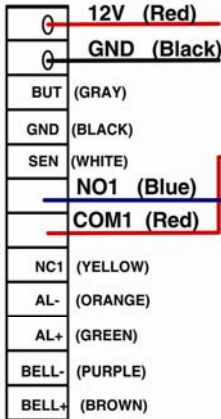

Power source options:

1. 12V and Gnd of Digital In 8 (not 1-7)
2. 12V and Gnd of Aux Pwr terminals
3. External 12V 1A power supply

DIGITAL IN

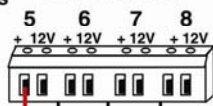

Authorized entry switch closure

Use min. 26AWG stranded wire up to 1000 Ft. for DIGITAL IN connections only

VIEW OF REAR OF ENVIROMUX-16D

AUX PWR

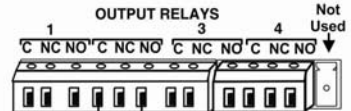

ENVIROMUX-EDR-SCR/
ENVIROMUX-EDR-SCF
(Depending upon your application)

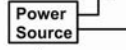

Electric Strike

Power source options:

1. 12V and Gnd of any Digital In (1-8)
2. 12V and Gnd of Aux Pwr terminals
3. External 12V 1A power supply

VIEW OF TERMINALS ON ENVIROMUX-5D

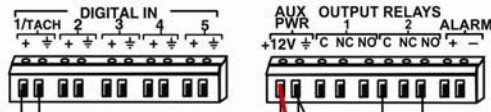

Authorized entry switch closure

COM1
NO1

ENVIROMUX-FACKR
Wiring Harness

12V
GND

Electric Strike

Power Wire Gauge Recommendations

Max.Length(Ft)	AWG
100	26
400	24
700	22
1000	20

For best performance, use stranded wire.

The ENVIROMUX-FACKR requires 110mA @ 12VDC to operate.

VIEW OF TERMINALS ON ENVIROMUX-2D

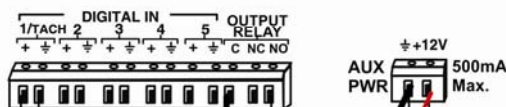

Authorized entry switch closure

ENVIROMUX-FACKR
Wiring Harness

AUX PWR
±12V
500mA Max.

12V ENVIROMUX-FACKR
GND Wiring Harness

Electric Strike

ENVIROMUX-EDR-SCR/
ENVIROMUX-EDR-SCF
(Depending upon your application)